

Unit IV Deep-Sea Sediment Coring

On the cutting edge...

Cindy Pilskaln is on the cutting edge of science using the latest technology to study the sediments that make up the deep-sea floor. Using various types of core sampling devices, she is able to collect undisturbed layers of sediment. When these sediments are carefully analyzed, they tell a story about the formation of the ocean bottom that can be related to global events. Dr. Pilskaln hopes to continue her research and learn more about the biological and chemical processes that contribute to sediment deposition on the ocean bottom.

The Story of Deep-Sea Sediments

Lesson Objectives: Students will be able to do the following:

- Describe two ways to classify ocean floor sediments
- Compare and contrast three sediment sampling devices
- Explain how sediments can be used to create a historical record

Key concepts: weathering, terrigenous sediment, biogenic sediment, core samplers, marine snow, chemical precipitates

Formation of Deep-Sea Sediments



The deep-sea ocean floor is made up of **sediment**. This sediment is composed of tiny particles such as fine sand, silt, clay, or animal skeletons

that have settled on the ocean bottom. Over long periods of time, some of these particles become compressed and form stratified layers. Scientists that study these layers look at particle size, particle composition, and origin to help them create historical records of the deep ocean floor.

Particle or grain size is determined by measuring the **diameters** of the

particles in **millimeters** (mm) or **microns** (=1/1000 of a millimeter). The particles from largest to smallest are gravel, sand, silt, and clay. Gravel can be as big as a boulder (>256 mm) or as small as a granule (2-4 mm). Silt (0.00039-0.0625mm) and clay (0.0002-0.0039mm) are very tiny particles that are generally mixed together to form mud. Most deep ocean sediments are silt and mud.

Most sediments form as rocks are broken down into smaller particles such as sand and clay. This process is



called **weathering**. Weathering can be either mechanical or chemical. Mechanical weathering can occur as ice, wind, or water wears away the rock's surface. Chemical weathering can occur as rocks are dissolved by a chemical such as acid rain. The particles created as a result of weathering are called **terrigenous** sediments. These particles are transported to the ocean by wind and by rivers and streams. Once the particles enter the ocean, they are dispersed by waves, **currents**, and **tides**. The heaviest and largest particles that reach the oceans, such as sand, settle very quickly to the bottom as a result of gravity. Sand is deposited near the coast whereas the smaller silt and clay particles are transported farther distances offshore before they settle to the bottom. Often, large deposits of sand and silt pile up at the edge of the continental shelf. If these piles of sediment are disturbed by underwater earthquakes, they will slide down the continental slope into the deeper ocean and produce a **turbidity current** of mixed sediment and water that moves along the ocean floor and is eventually deposited. This is the primary way in which sand is transported to the deep-sea where the sediments are made up of tiny silt and clay particles.



plants and tiny organisms. These sediments are called **biogenic** sediments.



Very small microscopic animals known as **zooplankton** feed on microscopic plants or **algae** called **phytoplankton** in the ocean surface waters. Phytoplankton and tiny organisms called **protozoans** in the ocean have beautiful skeletons made up of biogenic silica (a type of biological glass) and calcium carbonate (same composition as beach shells). The zooplankton filter large amounts of water each day, consuming microscopic algae and protozoans as well as small clay particles in the water.

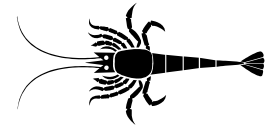

Zooplankton produce many fecal pellets as a result of their filter feeding activity and these pellets contain the skeleton remains of the tiny algae and protozoans, as well as lots of organic matter and often clay particles. Fecal pellets sink much faster than the particles contained in them and so they are able to transport the tiny particles to the deep-sea in a matter of weeks to months. Once the pellets reach the bottom, they break apart and their tiny particle contents become part of the deep-sea sediments. These fecal pellets and **marine snow** make up the material that sinks through the ocean, carrying organic food, clay minerals, and skeletons of biogenic silica and calcium carbonate to the sea floor,



Other deep-sea sediments originate as skeleton remains of microscopic

forming part of the bottom sediments. Marine snow consists of bits of dead as well as living algae and tiny organisms, as well as clay particles and fecal pellets that are held together with **mucus**. These mucus-bound particles are generally greater than 0.2 mm (or 200 μm) in size, and they can grow to be almost a meter (over 3') in diameter.

Scientists often think of marine snow as the "dust balls" of the ocean,

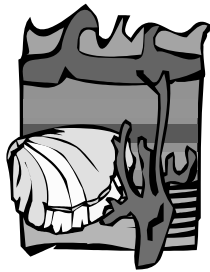

similar to dust particles in your house that pick up lots of little particles and can grow in size. Marine snow particles contain a large amount of

organic carbon from phytoplankton. Ocean phytoplankton consume carbon dioxide, as do all plants, in the process of photosynthesis. This process is responsible for removing carbon dioxide from the atmosphere to the ocean. The phytoplankton use the carbon dioxide to grow, thus producing organic carbon plant matter from atmospheric carbon. So, as the organic-rich marine snow and fecal pellets sink to the sea floor, they are basically transporting carbon originally from the atmosphere, to the ocean bottom.

Also caught up in the sinking, marine snow particles are the tiny

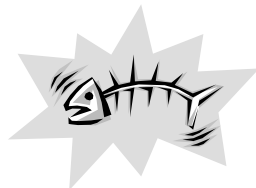

skeletons of silica and calcium carbonate produced by protozoans called radiolarians and foraminifera. The skeletons are often a millimeter

or less in size and have shapes that resemble tiny coiled shells or snowflakes. Over millions of years, these skeletons build up and accumulate in the deep ocean to become a major component of biogenic deep-sea sediments.



Additional deep-sea sediments are the product of chemical reactions that take place in the water column near or at the seafloor. These reactions can produce **precipitates** that form chimney structures, crusts, or **nodules**. Many of these chemical precipitate sediments are found in the deep Pacific and all are associated with submarine volcanic activity near or along submarine ridges. They were first discovered and sampled using small scientific **submersibles**. Chemical precipitate sediments often contain large amounts of heavy minerals such as manganese, zinc, and copper.

Occasionally, deep-sea sediments contain small amounts of volcanic ash from large eruptions occurring on the continents. The ash is transported long distances out to sea by winds and settles extremely slowly to the seafloor (taking many years), or more quickly if the ash becomes part of a fast-sinking fecal pellet or a marine snow particle. Marine geologists have also found dust from outer space deposited in some deep-sea sediments.



Sampling of Mud in the Sea

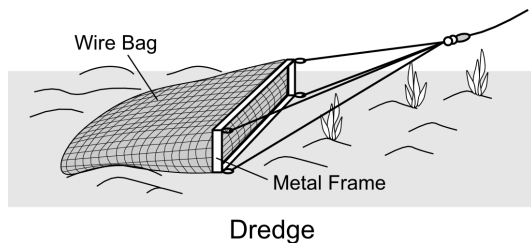

Dredge

Several types of technology are used to collect marine sediments from research ships. These devices include surface samplers and sediment corers. Surface samplers collect only the uppermost layers of the ocean floor. These devices include dredges and benthic grabs. Dredges are heavy nets attached to metal frames that are dragged along the bottom behind a ship. The nets themselves can be made of chain. Dredges are useful when collecting samples from hard surfaces such as the rocky bottoms of coastal ledges.

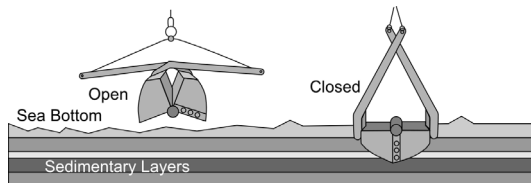

Benthic Grab Sampler

Benthic surface grab samplers look like giant metal jaws. They dig into the bottom and take a bite of the sediment. These samplers are good for collecting softer, sandy or silty sediments that do not contain rocks. A box corer is a cross between a surface sampler and a sediment corer. It is a special device that is used to collect an undisturbed sample of the very top surface layers and the sediment underneath. This corer collects a 1-2 foot thick "box of

mud". A box core usually contains some overlying water, a surface "floc" layer where newly deposited particles are suspended, and frequently the core collects some benthic animals such as worms and starfish. Box corers are used to collect mud and silt but not sand.

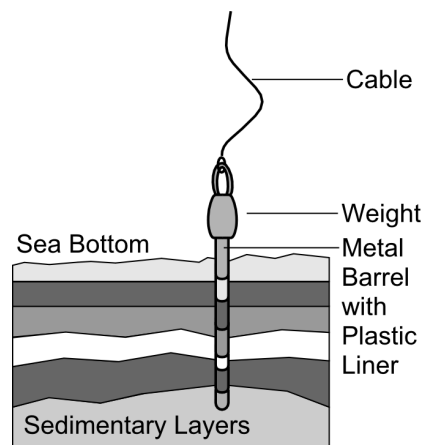

Gravity Corer

The most common types of sediment corer used by marine geologists to collect mud and silt are those that collect a tube of sediment. The tube of sediment collected can range in length from several feet to hundreds of feet. A gravity corer consists of a metal tube called a barrel, a plastic liner, and a heavy weight. The plastic liner is inserted into the metal tube before it is lowered over the side of the ship. This plastic liner will contain the sediment core when it is retrieved from the ocean floor. The corer is lowered



where the weight on the top drives the barrel and liner into the sediment. Gravity corers generally sample sediment layers up to 6 feet

long (or 2 meters). After collection, the sediment core within the hard plastic liner is slid out of the core barrel, caps are placed on both ends, and the core is stored in a large walk-in refrigerator. Scientists will split the core in half length-wise and sample sediment for various analyses from one half called the “working half”. The other core half is not sampled

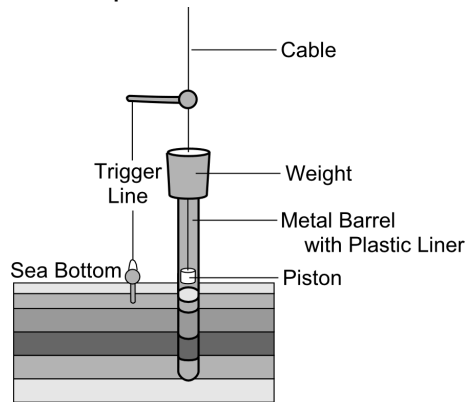

Piston Corer

but is saved as the “archive half”. Piston corers look like gravity corers, but they are much longer, much heavier and collect a longer core sediment. A cylindrical piston system at the top of the coring unit, which can slide down the core barrel with the help of weights, acts to drive the corer deep into the sediment. This gives scientists a very compact, long sediment core with very little water. Due to the force with which the piston core is driven into the mud, the very top is often lost and not sampled. However, this corer is able to penetrate much deeper into the seafloor, thus collecting much older sediments than what a gravity



corer or a box corer can obtain. This is because the deeper the sediment is below the surface of the seafloor, the older it is.

Several other types of coring devices are also useful to marine scientists. The multicorer punches 6 or more, 1-2' long tubes into the

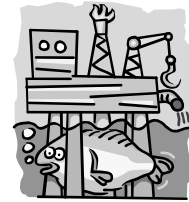

bottom, all at once. It also relies on gravity and weights and is most useful in sticky, muddy sediments. On a really big scale, the international Deep-Sea Drilling Project (DSDP) uses drilling technology from the oil and gas industry to obtain cores of 10's – 100's of meters long. These long cores give scientists an excellent overview of the geologic and oceanographic history over thousands of years. The cores are obtained from a

specialized ship, which was designed to operate like an

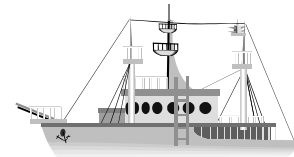

oil drilling platform used to collect oil from beneath the seafloor. Obtaining cores that are hundreds of meters long from a ship takes many hours. This process can be very challenging and occasionally dangerous! This is especially true when the seas are rough and/or there is a lot of ice in the areas such as in the Antarctic. In general, the success or failure of all types of sediment coring done from oceanographic research ships is very much dependent upon the sea state.

Today various types of underwater vehicles are also being used to collect sediment samples. Submersibles or **remotely operated vehicles** (ROVs) collect sediments using small push corers less than one foot long. These plastic tubes are pushed into the surface sediment by the submersible vehicle's/ROV's mechanical or hydraulic arm. The recovered sample is placed in a sample bucket or cage on the front of the underwater vehicle and is transported back to the ship. The

advantage to this type of sediment sampling is that the scientist, either inside the submersible or controlling the ROV with the use of cameras from the ship, can visually target the sampling site. All other shipboard coring methods described above are done "blindly"—the corer is lowered over the side of the ship to the seafloor without the scientist being able to see exactly what is being sampled.

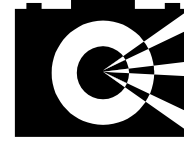

Earth Stories Told by Marine Sediments

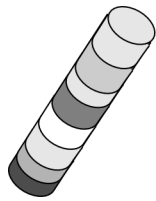

Scientists use many different methods to study deep-sea sediment cores. They photograph, sample, and physically describe the working half of the cores. If a sediment core contains obvious layers, they make observations about the layer sequence and calculate layer thickness. Scientists also perform many tests and analyses on the cores. Sediment samples from the core are placed on a glass slide (called a "smear slide") and examined under a microscope to determine sediment particle origin and composition.

The various amounts and types of skeleton remains of planktonic algae and organisms in the sediments give the scientists clues as to how warm or cold the ocean was in the past. They can also tell how productive the ocean was over long periods of time



above the seafloor by studying the planktonic skeletons and performing chemical tests on them. The types of minerals in the sediments help to determine how far terrigenous particles might have been transported from where they originated on the continent as a weathering product. This in turn tells scientists about the pathways of past ocean currents. The magnetic properties of mineral particles found in the sediments provide important clues about how the earth's magnetic field has changed over thousands to millions of years. Once marine geologists have the results of these and other tests, they can begin to piece together not only the geologic history of the seafloor, but of the ocean waters above it.



Ocean sediments are the final product of weathering and of

biological processes occurring in the ocean. This makes deep-sea sediment composition also a record of **climate** change on earth. This is because the weathering of rocks is extremely dependent upon climate, and because biological production in the world's oceans and its chemical composition

changes as the oceans heat up or cool down over thousands to millions of years. What

marine scientists are learning from studying deep-sea sediments is how climate change in the earth's past has affected the oceans.

Understanding these effects is helping scientists predict how the oceans and the earth will "act" in the future if for example, we continue to increase levels of carbon dioxide in the atmosphere causing a warming of the planet. Studies of ancient sediments and the **fossil** remains of marine organisms highly sensitive to changes in ocean temperature and chemistry provide clues about how certain

organisms survived through major climate



changes in the past. Scientists can use this information to predict how plants and animals might deal with future changes in the climate.

Sediment core research has unlocked scientific mysteries around the world. Scientists can trace the ~20,000-year history of the Black Sea using sediment samples. They can follow the seasonal cycles over thousands of years as the Black Sea basin evolved from a fresh water lake to a closed marine **anoxic** basin. Atlantic Ocean cores tell the history of the changing sea level due to the movements of the earth's crustal plates over millions of years. Antarctic Ocean cores of biogenic sediments from the continental shelf areas contain long-term records of marine phytoplankton production cycles. Maps of terrigenous sediments and minerals across the Antarctic continental shelves as obtained from sediment cores, trace the history of glacial movements and meteorite fall-outs over 10,000-15,000 years. These stories and others like them can help us piece together a better understanding of how the earth works so that we may learn what to expect in the future and how we as humans might be affecting the planet.

Activity: An Unsettling Experiment

The ocean floor is made up of materials that originate from land minerals, living organisms, volcanic ash, and even outer-space dust. All of these materials form particles of various sizes, shapes, and densities with identifiable properties.

These characteristics and the properties of the water help determine the settling rate of the particles. Scientists that study ocean bottoms use this information to help them analyze the ocean bottom sediment layers.

Objectives: Students will be able to do the following.

1. Measure settling time for various particles.
2. Analyze data to determine factors that contribute to settling rate.
3. Design an experiment to test a hypothesis.

Materials:

- Tall, transparent, watertight container (The container should be at least two feet tall. Various items can be used for the container. Large graduated cylinders work best, but other items can also be used. Plastic cylinders, recyclables, tall vases, hamster tubes sealed with PVC cement, or plastic bottles with wide necks will also work. When using plastic bottles, cut the bottom out of one and glue the two bottles together at the necks with hot glue.)
- Stopwatch
- Paper/pencil
- Recording chart, computer, or paper
- Particles for testing-cookie sugars and sprinkles of various shapes and sizes, jelly beans, gum drops, and M & M's
- Ruler with metric measure

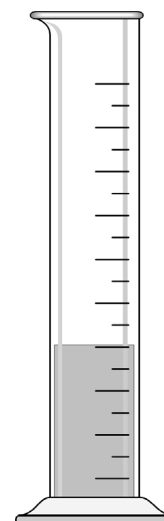

Procedure:

1. Discuss the factors involved in settling rates of various particle types. Include the concept of size, shape, and density as some of the factors affecting the outcome.
2. Divide students into groups.
3. Give each group a cylinder, stopwatch, and particles.
4. Have students fill the cylinders with water.
5. Have students accurately measure the distance from the surface of the water to the bottom of the container in centimeters.
6. Demonstrate how to use a stopwatch.
7. Have students put various particles into the cylinder one at a time. (Smaller particles like cookie sugars can be sprinkled in a few at a time.)
8. Measure the time it takes for the particles to settle to the bottom of the container. Record the results.

9. Have students measure the diameter of each particle. (In the case of odd shaped particles have the students estimate.)
10. Have students graph the results plotting settling time against diameter size.
11. Discuss any correlation between the two measurements. What other factors need to be considered when determining settling rate?
12. Have students observe the particles on the bottom of the container. Is there a particular layering pattern? Are some particles completely dissolved?
13. Have students analyze their results-How does dissolvability affect results? What is that similar to in real life?
14. Discuss results as a group.
15. Have students create new experiments to test questions that they raise during the discussion. Use these experiences to clear up misconceptions.

Possible Extensions:

1. Experiment by changing another parameter of the original experiment. Some suggestions include:
 - Use water of different depths.
 - Use containers of various shapes.
 - Use moving water.
 - Use other types of settling materials.
 - Fill cylinder with vegetable oil or liquid soap.
2. Gather information about Stokes Law. How could this information be used to determine settling rates for various particles?

Student Information: Deep-Sea Sediments



Sediments that make up the ocean floor can come from

several sources. **Weathering** causes rocks found on land to break down into sand, silt, and clay. These particles can be carried to the ocean by wind or water. Once in the ocean, these particles sink to the bottom and become part of the ocean sediment. Marine plants and animals also contribute to the sediments in the form of fecal pellets and **marine snow**. Deep-sea sediments may also be formed from chemical reactions occurring near the bottom when seawater reacts with certain types of rocks on the seafloor. Additionally, some deep-sea sediments contain particles from volcanic eruptions on land and even dust from outer space.

Over millions of years, these particles settle to the bottom and form sediment layers that can tell stories about the geologic past. Some sediments reveal how canyons and ridges were formed on the ocean floor. Other sediments tell us about the kind of organisms that lived

in the ocean millions of years ago. Still others can tell us about the movement of glaciers or the changes in sea level.

To read these stories, scientists must collect samples from the ocean floor without disturbing the sediment layers. To collect such samples, scientists use surface samplers and coring devices. Surface samplers collect sediment from the very top layers of the ocean floor. These samples may contain some water and even animals hidden in the muddy bottom. Coring devices collect long cylinders of sediment called cores. These cores often show that sediment layers have different colors and textures. Marine geologists carefully sample and study the cores using microscopes and chemical tests. Results of these studies tell scientists that a lot has changed in the world's oceans over millions of years. This information helps us understand the geologic past, so that we can learn how to protect our planet in the future.

